

Authenticated Automated Teller Machine Using Raspberry Pi

¹P. Jegadeeshwari, ²K.M. Haripriya, ³P. Kalpana, ⁴K. Santhini

Department of Electronics and Communication, C K college of Engineering and Technology.

Author's mail id: jegadeeshwari25@gmail.com, khariPriya2903@gmail.com

Abstract: In recent day's fraud attaching in ATM is a major issue which tremendously affect the social and mental well being of a person. Our proposed paper is a key idea to reduce the crime activities and usage of ATM by irrelevant people to handle one's account. We use biometric identifications such as face and iris recognition implemented using Raspberry pi, which are more secured when compared to other physical recognition methods. When the user fails to pass the verification process twice, the ATM door will be locked automatically. The user can only leave the ATM when the security enters the OTP send to his mobile through GSM.

Keywords: Raspberry Pi, Iris sensor, Webcam, GSM module.

Acronyms: ATM- Automated Teller Machine, GSM- Global System for Mobile communication, IC- Integrated Circuit, OTP- One Time Password.

1. INTRODUCTION

The development in technology and trend ATM's are widely used right from 21th century itself, but actually ATM was introduced in the year 1967 in London. Within 50 years it reached all over the world and was used by several millions of people. In earlier days ATM's were only used to withdraw cash and report about the dispatchment of the money, only few complex machines allow deposits and bank statements which came to existence before few decades.

Currently we are using credit/debit cards to withdraw money and fingerprint/thumb print recognition technique to access one's account. But these techniques possess several disadvantages. Our proposed paper is a satisfactory method to overcome the issues faced in previous methods.

2. EXISTING SYSTEM

When discussing about the existing methods, there are two major types. Firstly accessing the account using cards (debit/credit). Secondly by thumb/finger print access. Though these two methods are widely used it has several disadvantages as given below.

- Allows irrelevant people to access the account, once if they know the password. This likely occurs in case of withdrawing money using credit/debit cards
- Online money transactions can be done easily by just entering the card number and cvv number. (Which will be given the card itself).
- In case of finger print access, the person with wound or injury will face difficulties in accessing their account.
- Sometimes position of the finger while passing verification may fail due to mismatch in position when compared to print stored in database.
- It's a time consuming process and need several monitoring features and regular checking.

3. PROPOSED SYSTEM

The advent of fast growing technologies makes users to have high security systems with electronic identification options. These identification technologies include ATM and other intelligent cards, user IDs and password based systems, and so on. But, unfortunately these are unsecure due to hacker attacks, thefts, and forgotten passwords. In spite of all these shortcomings and malfunctions these systems are still prevailing; however, the authentication based on iris and face identification is the most efficient and reliable solution for stringent security in this system, a raspberry pi based prototype.

Our proposed system is the method of accessing the ATM by face and iris recognition instead of traditional card and fingerprint method. Iris recognition is one of the methods with high security because iris of each and every person is unique and can't be easily duplicated until it is changed in the database of the banking system. Iris and finger prints of a person do not change in any instant. But fingers are easily subjected to injury and maintaining database 2or3 the fingers is also tedious process and consumes more memory space. This problem will be less in case of iris because human eyes don't get easily damaged and maintaining database is also very easy.

The below table represents the degree of security with existing and proposed systems.

Biometric Identification	Uniqueness	Permanence	Database
Thumbprint	High	High	Low
Audio	Low	Low	Low
Face	Low	Low	High
Iris	High	High	Low
Palm Signature	Low	Low	High
Hand Gesture	Low	Low	High

Fig 1: Degree of security

The design of the authenticated Automated Teller Machine is implemented using Raspberry Pi as the main processing and controller board. The security of the system is enhanced by face and iris recognition technique. The iris recognition is done by circular Hough algorithm and face identification is implemented using Haar algorithm. The GSM is used for OTP mechanism, which is directly connected to the Pi board by serial communication.

4. BLOCK DIAGRAM OF PROPOSED SYSTEM

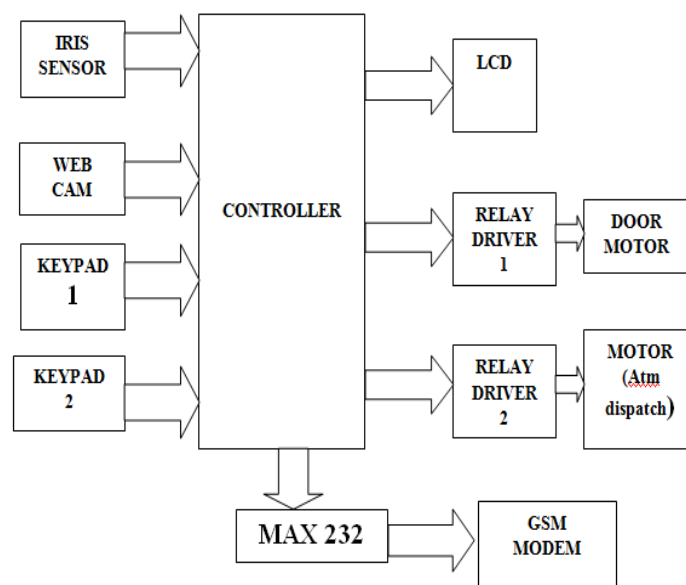

Fig 2: BLOCK DIAGRAM OF ATM USING RASPBERRY PI

(a) IRIS recognition using circular Hough algorithm.

Iris recognition system is below Fig.3 the first step of the system is to capture the eye image, captured image is then send for preprocessing. The main aim of preprocessing is to check the quality of captured images, then quality of the images if it is good then first locate the iris in captured image and if the quality of images is not good then need to do improvement. Iris image pre processing is categorized into three steps: iris localization, iris normalization and image improvement.

Center of the pupil is poor quality to iris. Pupil radius ranges from 0.1 to 0.8 of iris radius. Isolation of the region from the eye image is mainly concerned with acquisition of image. Aim of image acquisition is to get quality image.

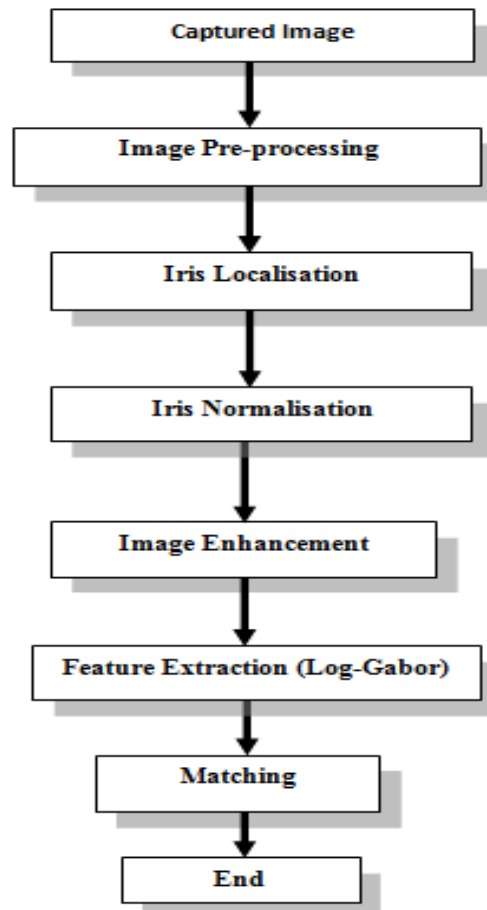

Fig 3: Steps for iris recognition

Iris Localization

Localization detects the inner and outer boundaries of the iris. The most important step is both the inner and outer iris boundaries can be approximately modeled as circles and correct iris portion is necessary to generate templates. Iris localization is classified into four different techniques discussed in this section.

Circular Hough Transform

The general Hough convert can be used on any kind of shape although the complexity of the transformation increases with the number of parameters needed for describing the shape of an image. Circular Hough convert is used to detect the iris boundaries. First, the conversion of point in each (x, y) space is done into the corresponding Hough parameter space. The circle is meeker to represent in parameter space, matched to the line, since the parameter of the circle can be straight transferred to the parameter space points (a, b, r). As it can be seen the circle to get three parameter r, a and b, where a & b are the center of the circle in the direction x & y respectively and r is the radius.

Hough transform votes are cast in three direction accumulator. To select the proper scale of edge analysis and to smooth the image Gaussian filter is applied. More the number of cells more will be the accuracy, Accuracy depends upon the number of accumulator cells.

Bisection method

In this Method, the center of the pupil is located by using bisection method. An iris Image is to extract the edge information by applying edge detection. The perpendicular lines are drawn through the center point y by applying bisection method. The radius is increased within a certain range and virtual circle is drawn with reference to the center of the pupil. It is affected by the non uniform illuminations and glasses reflections.

Iris Normalization

The process of normalization is remapping images from Cartesian coordinates to polar coordinates and creates fixed dimension iris images. In iris image Pupil size may vary in illumination due to the contraction of pupil in light. A person's same eye the different iris images of may appear different due to conditions under which they were taken. By using fixed parameter interval Daugman normalized the iris image by representing the image in a doubly dimensionless pseudo polar coordinate system. The segmented iris region is normalized in order to obtain a fixed number of features from the iris regardless of its spatial resolution. And Map the iris to a dimensionless fixed coordinated system that is invariant to size changes, i.e. pupil dilation and iris size changes.

Image Enhancement

The process of improving the advantage and contrast of an image is known as image enhancement. The normalized image needs to advance because usually it is of low contrast non-uniform illumination caused by the light source position. It does not affect for matching stages and further dealing out.

The whole image of intensity variation is approximated to get well distributed texture figure. Further dealing out is accomplished by the histogram equalization. The contrasts of the image improve this processing which is then used for outline matching and feature extraction.

Feature Extraction

Feature extraction is the first and most important step in image classification. Latest available image classification methods apply hand-crafted features, which are not adaptive for a variety of image domain. Feature extraction is the main part of iris recognition system.

Log Gabor Filter

Iris features extracted by using 2D Gabor filters are used in both [1] and [2]. 1D Log-Gabor filters are convolved the image because the first reason is they provide phase information. And second is they are constructed by modulating sine's and cosines waves with a Gaussian filter which makes them useful for localizing in space and frequency. Phase information of each Iris pattern is extracted with the help of quadrature 2D Gabor wavelets. The phase information is quantized into four quadrants in the complex plane.

Performance parameter

The performance parameter could be recognition rate, time complexity and space complexity. Recognition performance has many measurement standards. The most important and popular formula are recognition rate is the ratio of Number of recognized images to Number of testing images.

Recognition Rate or accuracy can be defined as the percentage of total successfully classified samples out of total tested samples. Accuracy can also be measured in terms of FAR (False Acceptance Rate) and FRR (False Rejection Rate) False Acceptance Rate is the percentage of total other person samples those were misclassified as the current samples. False Rejection Rate is the percentage of two samples those were recognized as another person than the true person.

(b) Face Detection Methodology

The face detection algorithm contains different methodology for detecting the face. The primary methods for face detection are Haar based algorithm and Local Binary Pattern based algorithm (LBP). In the projected system, the face is detected from the image using Haar cascade feature. Face Detection using Haar is a machine learning based approach where a cascade function is trained from a lot of positive and negative images.

Viola and Jones are the one who originated the idea of using Haar wavelets and developed the so-called Haar-like features. A Haar-like feature considers adjacent rectangular regions at a specific location in a detection window, sums up

the pixel intensities in each region and calculates the difference between these sums. This difference is then used to categorize subsections of an image. For example let us say we have an image database with human faces. It is a common observation that among all faces the region of the eyes is darker than the region of the cheeks. Therefore a common Haar feature for face detection is a set of two adjacent rectangles that lie above the eye and the cheek region. The position of these rectangles is defined relative to a detection window that acts like a bounding box to the target object.

The Haar cascade files are supported in the OpenCV. OpenCV comes with a trainer as well as detector. Here we will deal with detection. The XML files are stored and used to compare for detection using inbuilt functions.

5. CONCLUSION

The use of the biometric as a password has made the ATM transaction system more reliable and secured. The OTP concept added to the system further enhances the security and avoids the need for us to remember passwords. Moreover the system is built on embedded technology which makes it user-friendly and non-invasive. Using this system the ATM terminal is secured from fire and thief attacks. Previous ATM transaction systems have less accuracy and security, were the proposed system is much safer and quick process and reaches accuracy up to 95%.

REFERENCES

- [1] *A Face Detection Algorithm Based on Adaboost and New Haar-Like Feature*. 978-1-4673-9904-3/16/\$31.00 ©2016 IEEE.
- [2] *Recognizing Debit Card Fraud Transaction Using CHAID and K-Nearest Neighbor: Indonesian Bank Case*. 2016 11th International Conference on Knowledge, Information and Creativity Support Systems (KICSS), Yogyakarta, Indonesia (IEEE 2016)
- [3] *Study of Raspberry Pi 2 Quad-core Cortex-A7 CPU Cluster as a Mini Supercomputer*. 2016 8th International Conference on Information Technology and Electrical Engineering (ICITEE), Yogyakarta, Indonesia (IEEE 2016)
- [4] *Automated Iris Recognition System: An Overview*. International Journal of Computer Applications (0975 – 8887) Volume 115 – No. 17, April 2015
- [5] *Design and Implementation of Anti-theft ATM Machine using Embedded Systems*. 2015 International Conference on Circuit, Power and Computing Technologies [ICCPCT] (IEEE 2015)
- [6] *Arm 7 based multi level security for atm access using finger print and gsm technology*. International Journal of Advance Research In Science And Engineering <http://www.ijarse.com> IJARSE, Vol. No.3, Issue No.9, September 2014
- [7] *ATM Client Authentication System Using Biometric Identifier & OTP*. Jaydeep Shamdasani et al Int. Journal of Engineering Research and Applications www.ijera.com ISSN : 2248-9622, Vol. 4, Issue 4 (Version 5), April 2014, pp.74-78
- [8] *Experimental Study of Thumbprint-Based Authentication Framework for ATM Machines*. Science and Information Conference 2014 August 27-29, 2014 | London, UK
- [9] *Establishing user trust in automated teller machine Integrity*. IET Inf. Secur., 2014, Vol. 8, Iss. 2, pp. 132–139 doi: 10.1049/iet-ifs.2012.0220
- [10] *Efficient Biometric Iris Recognition Using Hough Transform With Secret Key*(2014) www.ijarcsse.com
- [11] *Design and implementation of Security based atm using arm11*.(IEEE 2014)
- [12] *The mCard approach for Bangladesh 16th Int'l Conf*. Computer and Information Technology (IEEE 2013)
- [13] *Privacy Protection on Transfer System of Automated Teller Machine from Brute Force Attack*.2012 26th International Conference on Advanced Information Networking and Applications Workshops.(IEEE 2012)
- [14] *Real Time SMS-Based Hashing Scheme for Securing Financial Transactions on ATM Systems*. 3rd IEEE International Conference on Adaptive Science and Technology (ICAST 2011) (IEEE 2011)